

# **I**MEADRAIN TRAFFIC DRAINAGE SYSTEMS FOR ROAD AND HIGHWAY CONSTRUCTION



## **HIGH QUALITY POLYMER CONCRETE DRAINAGE SYSTEMS**

PROFESSIONAL DRAINAGE SOLUTIONS FOR ROAD AND TRAFFIC APPLICATIONS

MEADRAIN DM / MEAKERB





**I**MEADRAIN TRAFFIC  
MONOLITHIC DRAINAGE CHANNEL  
FOR HEAVY TRAFFIC AREAS

# MEADRAIN DM SYSTEM OVERVIEW



Clear width: 100 mm  
Total width: 133 mm  
Total height: 225 mm

**MEADRAIN DM CITY 1000**



Clear width: 150 mm  
Total width: 183 mm  
Total height: 233 mm

**MEADRAIN DM CITY 1500**

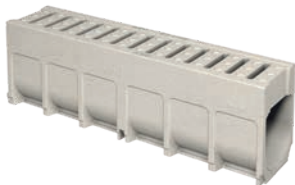

Clear width: 200 mm  
Total width: 270 mm  
Total height: 330 mm

**MEADRAIN DM CITY 2000**



Clear width: 100 mm  
Total width: 154 mm  
Total height: 265 mm

**MEADRAIN DM 1010**



Clear width: 150 mm  
Total width: 204 mm  
Total height: 280 mm

**MEADRAIN DM 1500**



Clear width: 200 mm  
Total width: 254 mm  
Total heights: 320/420 mm

**MEADRAIN DM 2000/2020/2040**

- > Channel section without fall
- > Monolithic construction
- > Loading class A 15 to D 400 \*\*

- > Channel section without fall
- > Monolithic construction
- > Loading class A 15 to D 400 \*\*

- > Channel section without fall
- > Monolithische Bauweise
- > Loading class A 15 to D 400 \*\*

- > Channel section without fall
- > Monolithic construction
- > Loading class A 15 to F 900 for standard variant
- > Loading class A 15 to D 400 with side inlets for use in open porous asphalt

- > Channel section without fall
- > Monolithic construction
- > Loading class A 15 to F 900 for standard variant
- > Loading class A 15 to D 400 with side inlets for use in open porous asphalt

- > Channel section without fall
- > Monolithic construction
- > Loading class A 15 to F 900 for standard variant
- > Loading class A 15 to D 400 with side inlets for use in open porous asphalt

\*\*From loading class D 400 not suitable for cross drainage of high speed roads and motorways.



## MEAKERB 320 AND 500 SYSTEM OVERVIEW



Clear width: 100 mm  
 Total width: 154 mm  
 Total heights: from 195 to 375 mm

**MEAKERB 320**



Clear width: 100 mm  
 Total width: 154 mm  
 Total height: from 375 to 555 mm

**MEAKERB 500**

- > Monolithic drainage system with top kerb profile, without fall
- > Monolithic construction
- > Loading class A 15 to D 400\*\*

- > Monolithic drainage system with top kerb profile, without fall
- > Monolithic construction
- > Loading class A 15 to D 400\*\*

\*\*From loading class D 400 not suitable for cross drainage of high speed roads and motorways.



## **I**MEADRAIN TRAFFIC PIONEERING DRAINAGE SOLUTIONS FOR MOTORWAYS AND CITIES

MEA offers you pioneering solutions for the reliable and cost-effective drainage of all the world's roads. Our product range contains clearly designed, and innovative solutions made of polymer concrete.

No matter which channel system you use for the task in hand, MEADRAIN TRAFFIC delivers decades of MEA expertise in professional surface drainage for every conceivable application. Optimize your planning with flexibility through innovative modular systems, a free technical support and advisory service and the outstanding physical and chemical properties of polymer concrete. Work with less weight, do away with heavy lifting equipment for installation, and benefit from the durability and reliability of our products.

### **MEADRAIN DM**

> For the drainage of motorways and highways

### **MEAKERB**

> Combines a channel and kerb profile in a single element for the drainage of roads, car parks and the streetscape of urban areas

# MEADRAIN DM

## THE HIGH-END MONOLITHIC DRAINAGE SOLUTION

### MONOLITHIC POLYMER CONCRETE DRAINAGE CHANNEL MEADRAIN DM

The monolithic high performance MEADRAIN DM has been designed to resist perfectly and on the long run to maximum traffic load. As an alternative to our heavy duty DM channels our MEADRAIN DM CITY has been designed for urban areas (Loading class D 400\*\*, wheelchair compatible).

\*\* From loading class D 400 not suitable for the cross drainage of high speed roads and motorways.

### Fields of application:

- > Motorways
- > Highways
- > Airports

### The monolithic construction of the MEADRAIN DM

#### guarantees:

- > Maximum acceptance and transfer of high dynamic loads
- > Total compliance with safety and security standards
- > Best possible value for money

Made from high compressive- and tensile-strength polymer concrete

Suitable for use in highway constructions: resistant to aggressive abrasion, premature ageing and de-icing salt. Completely frost-proof and very hard-wearing

100% traffic safe: no loose components such as bolts or metal parts

Eco- and climate-friendly, as the material used contains approximately 90% mineral aggregates

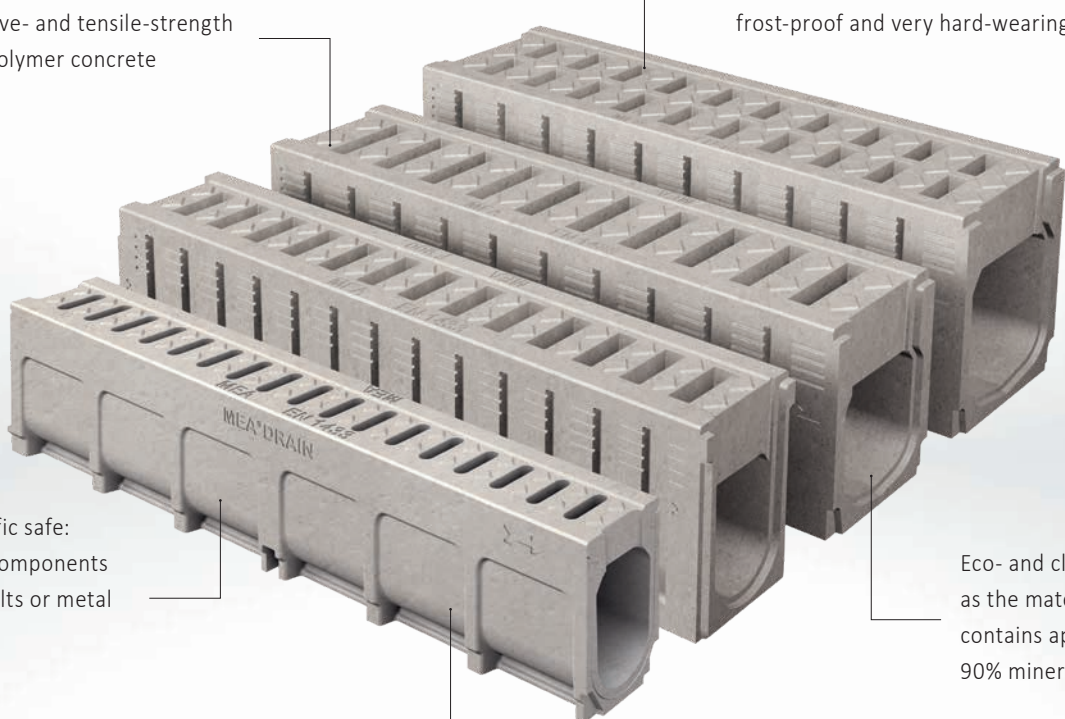

MEADRAIN DM CITY  
in clear widths: 100, 150 and 200 mm,  
loading class up to D 400\*\*

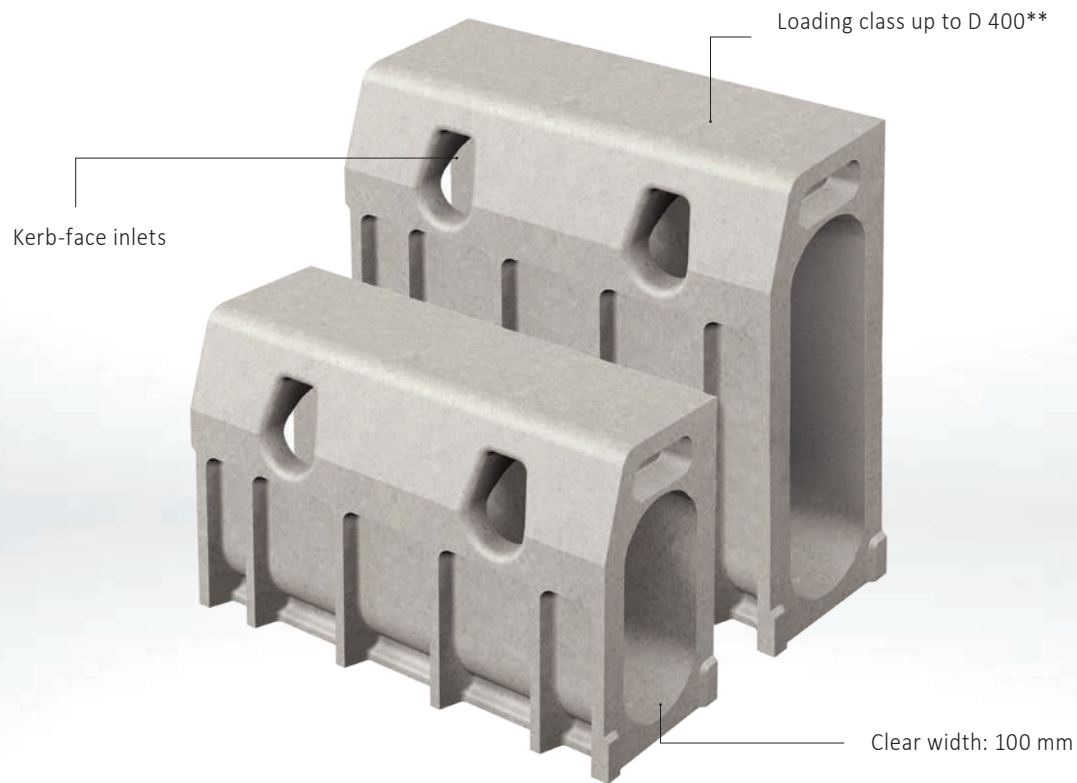

## MEAKERB THE KERB WITH INTEGRATED WATER DRAINAGE FACILITY

The new MEAKERB generation benefits from the profound knowledge of our engineering department and is now available in a monolithic construction making it not only sturdier but also more economical.

**The MEAKERB has been designed for following applications:**

- > Major highways
- > Rural and urban roads
- > Roundabouts
- > Property access roads
- > Flyovers
- > Car parks
- > Lay-bys
- > Bus stations

Drop-kerb and centre stone units for access roads, plus a complete range of accessories make the MEAKERB module in conjunction with the MEA Planning Service a perfect all in one solution for fast and professional installation. Last but not least: If a single kerbstone becomes damaged, it can be replaced individually – without costly groundwork operations.

**Elements MEAKERB 320 & 500:**

- > Bus stop kerb unit
- > Standard kerb unit
- > Centre stone unit
- > Road level compensation

\*\*From loading class D 400 not suitable for cross drainage of high speed roads and motorways.



# IMEA RAIL SOLUTION

## CUSTOM MADE SOLUTIONS FOR RAIL PROJECTS

### Efficient, intelligent and flexible

Customised and professional solutions for your specific applications:

- > MEADRAIN ENS 2010 and MEARIN EXPERT 200 channels and cover gratings in special lengths, designed to be installed across tramways
- > Comprehensive project support by experienced MEA technicians
- > MEA is the specialist for all TRAM projects whatever the power supply system used (over the ground (APS), or over headlines)





# I POLYMER CONCRETE

## THE QUALITY MATERIAL

### MEA POLYMER CONCRETE

The special polymer concrete from MEA is remarkable for its outstanding physical and chemical properties. These make it an extremely reliable and versatile material in even the toughest conditions.

MEA polymer concrete channels are particularly eco-friendly. Mostly made out of minerals, polymer concrete channels are easy to recycle. Because of the quality material channels have a particularly long lifetime, saving future investments and unnecessary new building sites.

Polymer concrete channels are the more extremely resistant to liquid chemicals and acids, making them the perfect protection devices for the environment and ground waters.

Last but not least, polymer concrete channels are significantly lighter than comparable concrete channels, making them considerably easier to install.

### MATERIAL CHARACTERISTICS

Compressive strength	> 90 N/mm <sup>2</sup>
Flexural tensile strength	> 22 N/mm <sup>2</sup>
Water adsorption	Below 0.05 %
Modulus of elasticity	25-35 kN/mm <sup>2</sup>
Density	2.1 - 2.3 kg/dm <sup>3</sup>
Water ingress depth	0 mm
Material structure	Capillary-free – ideal for the rapid discharge of water and dirt particles
Channel body weight	Significantly lighter than conventional concrete channels
Workability	Suitable for grinding disks, rock drills and chisels
Environmental compatibility	Eco-friendly building material with mineral admixtures
Ageing resistance	Entirely frost proof, wear-resilient, and maintenance-free. Highly resistant to liquid chemicals (pH range 3 to 9)

# THE ADDITIONAL PRODUCT PORTFOLIO OF MEA WATER MANAGEMENT

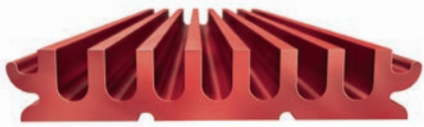

**MEARIN PG EVO**  
Drainage solution for multi-storey car parks

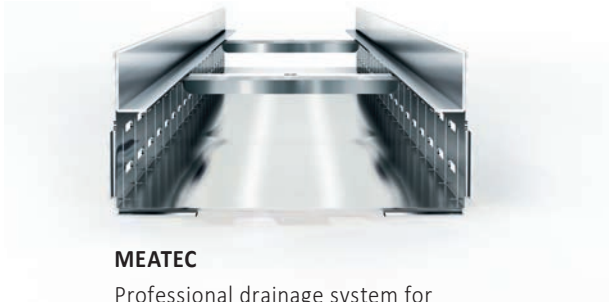

**MEATEC**  
Professional drainage system for facades and terraces



**MEARIN**  
Professional lightweight drainage system made of GRP



**MEADRAIN TRAFFIC**  
Professional drainage systems for streets and motorways



**BUILDING SUCCESS**

MEA Bautechnik GmbH ■ Sudetenstraße 1 ■ D-86551 Aichach ■ [www.mea-group.com](http://www.mea-group.com)  
Business unit MEA Water Management